

## Electro-Permanent Magnetic Circular Chuck

SAV 244.72

### With concentric pole arrangement

These circular magnets with concentric magnetic poles permit the clamping of several workpieces outside the central region. The strong magnetic field is distributed evenly over the entire surface.



### Use:

Mainly for precision grinding of small to large workpieces on rotary tables and cylindrical grinders.

Because of the concentric pole arrangement it is also suitable for holding groups of randomly placed mass-production pieces.

- for circular grinding
- uniform holding force distribution due to concentric pole arrangement; therefore suitable for thin and flat workpieces (e.g. saw blades)



- multiple workpiece operation on segments possible

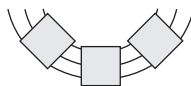

- for workpieces with min. thickness = x:  
2 mm at P = 4.5 mm  
4 mm at P = 9.0 mm  
8 mm at P = 18.0 mm

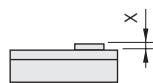

- for flat workpieces with min. dimensions 45 mm x 45 mm

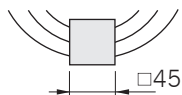

### Nominal holding force:

P = 4.5 mm:	80 N/cm <sup>2</sup>
P = 9 mm:	100 N/cm <sup>2</sup>
P = 18 mm:	110 N/cm <sup>2</sup>

adjustable by control unit with encoded switch

### Nominal operating voltage:

210 V DC up to 500 mm diameter  
360 V DC above 500 mm diameter

### Features:

- gap free construction of pole plate
- evenly distributed, strong magnetic field
- solid constructed pole plate
- switching off through demagnetizing cycle
- electro-permanent system, guaranteeing safe operation during power failure
- high precision due to fine grid pole-plate-to-body connection
- pole separation with brass in-lays for optimal wear behaviour
- pole plate exchangeable
- pole plate wearing limit 8 mm
- sealed to IP 65
- suitable for use with control unit type 876.10 (see chapter 04)
- available with adapter flange on request (SAV 248.90 to 248.94, see chapter 06)

### Scope of supply:

- Lifting bolts for transportation on larger models.
- Terminals for electrical connection in middle of backside in standard execution.
- Optional with integrated slip ring body for the bigger diameters.

## Electro-Permanent Magnetic Circular Chuck

SAV 244.72

With concentric pole arrangement

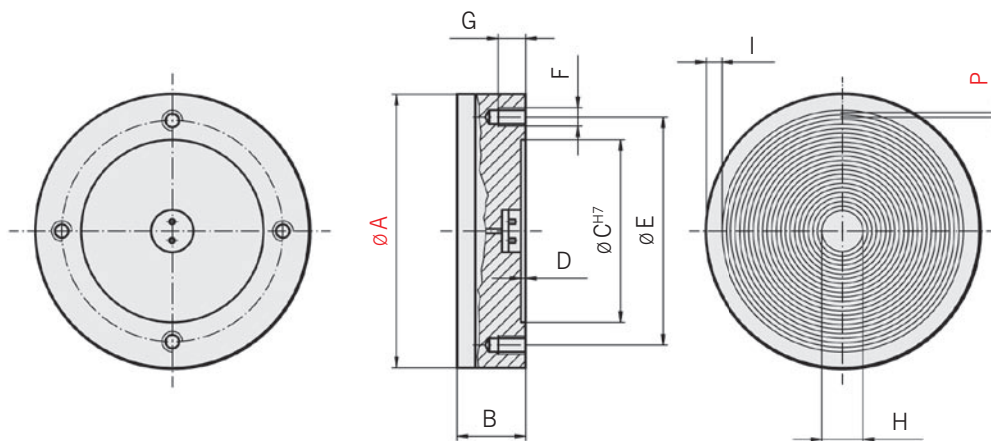

Dimensions in mm										Weight in kg	Chuck voltage in Vdc	Control unit max. current in A	Suitable control unit
A	B	C	D	E	F	G	H	I	P				
300	105	160	3	190	M12 (4x)	16	76	16	4.5	52	210	30	876.10
400	105	210	4	250	M12 (6x)	16	90	21	9	89	210	30	876.10
500	105	280	4	320	M12 (6x)	16	96	21	9	141	210	30	876.10
600	105	350	4	390	M12 (6x)	18	80	21	9	204	360	30	876.10
700	105	400	4	450	M12 (6x)	18	96	21	9	278	360	30	876.10
800	105	450	4	500	M16 (6x)	18	96	22	9	383	360	30	876.10
1000	105	550	4	620	M16 (8x)	18	96	22	9	578	360	60	876.10
400	105	210	4	250	M12 (6x)	16	66	21	18	89	210	30	876.10
500	105	280	4	320	M12 (6x)	16	92	21	18	141	210	30	876.10
600	105	350	4	390	M12 (6x)	18	70	21	18	204	360	30	876.10
700	105	400	4	450	M12 (6x)	18	92	21	18	278	360	30	876.10
800	105	450	4	500	M16 (6x)	18	92	22	18	383	360	30	876.10
1000	105	550	4	620	M16 (8x)	18	92	22	18	578	360	60	876.10
1200	125	Rear detail as required				22	80	23	9	990	360	60 x 2	876.10
1400	125	Rear detail as required				22	166	26	9	1350	360	60 x 2	876.10
1500	125	Rear detail as required				22	166	26	9	1550	360	60 x 2	876.10
1600	125	Rear detail as required				22	166	26	9	1765	360	60 x 2	876.10
1200	125	Rear detail as required				22	70	23	18	990	360	60 x 2	876.10
1400	125	Rear detail as required				22	166	26	18	1350	360	60 x 2	876.10
1500	125	Rear detail as required				22	166	26	18	1550	360	60 x 2	876.10
1600	125	Rear detail as required				22	166	26	18	1765	360	60 x 2	876.10

Larger sizes on request. Please refer to SAV 876.03 to SAV 876.10 (see chapter 04), for details regarding suitable control units, based on the power rating.

Ordering example: **Electro-Permanent Magnetic Circular Chuck SAV 244.72 - 1600 x 18 - 360 V**  
 Ordering key: Name SAV - No. - A x P - Operating voltage