



WORKHOLDING AND AUTOMATION

MAGNET PALLET

SAV 220.30

Material:

Aluminium base with St 37 /
stainless steel (V4A) Pole plate

Application:**Technical Specifications:**

- Parallelism: < 0.02 mm
- Can be executed with threaded holes for side or angled stops
- Magnetic field height: 4 mm
- Pole plate wearing limit: 3 mm
- Holding force: 80 N/cm²
- Pole pitch: 1.9 mm

System	Dimensions (mm)				Switchable sections	Weight (kg)
	A	B	C	D		
200	200	200	46	–	1	15.0
240	240	240	46	204.5	2	19.0
280	280	280	67	204.5	2	25.0
320	320	320	58	246.0	2	32.0
320	320	160	58	246.0	1	16.0

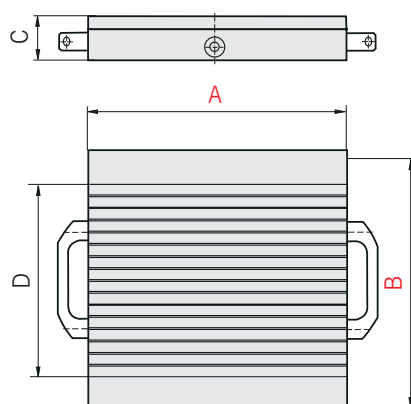
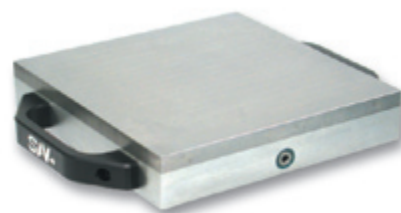

Ordering example: Magnet Pallet SAV 220.30 - 320 x 320 - Reference system* - Adaptation*
Ordering key: Name SAV-No. - A x B - Reference system* - Adaptation*

POWER MAGNET PALLET

SAV 220.31

Material:

Aluminium base with St 37 /
stainless steel (V4A) Pole plate

Application:

and High Speed Cutting (HSC)

Technical Specifications:

- Low weight with high holding force
- Parallelism: < 0.02 mm
- Pole plate wearing limit: 2 mm
- Holding force: 140 N/cm²
- Also available in stainless steel
- Can be executed with threaded holes for side or angled stops
- Low magnetic field height

Important:
Workpiece does not require
full magnetic surface!

System	Dimensions (mm)						Switchable sections	Weight (kg)
	A	B	C	D	E	F		
240	240	240	60	126.0	70.0	70.0	1	18.0
280	280	280	60	166.0	80.0	80.0	2	21.5
320	320	320	67	206.0	80.0	80.0	1/2	25.0

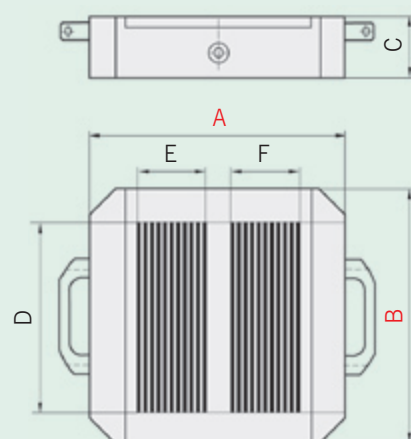

Ordering example: Power Magnet Pallet SAV 220.31 - 320 x 320 - Reference system* - Adaptation*
Ordering key: Name SAV - No - A x B - Reference system* - Adaptation*



WORKHOLDING AND AUTOMATION

APPLICATION EXAMPLES

Pallet type:
Magnet Pallet

SAV 220.30 - 320 x 320
Reference system*

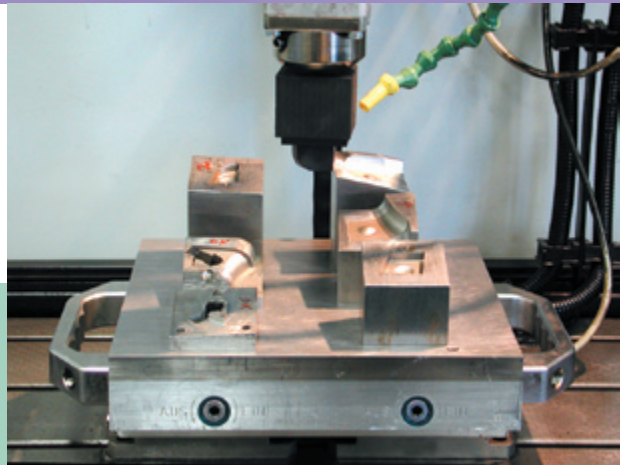
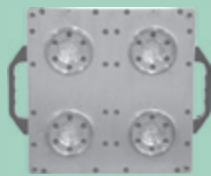

Pallet type:
Magnet Pallet

SAV 220.30 - 240 x 240
Reference system*

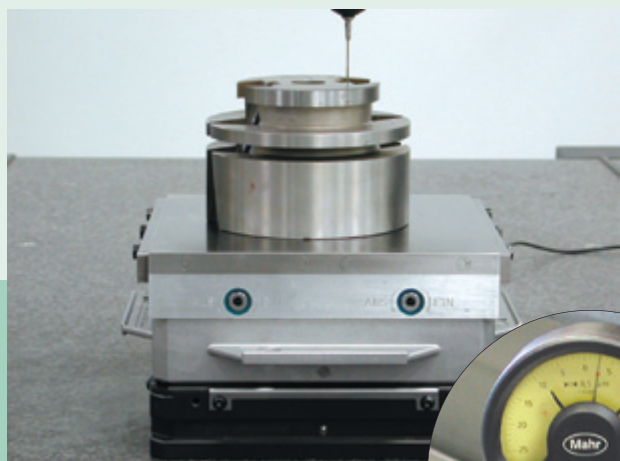
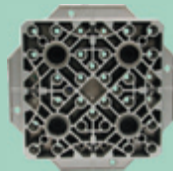

Pallet type:
POWER Magnet Pallet

SAV 220.31 - 320 x 320
Reference system*



*Please specify reference system and robot adaption;
we can advise!

Pallet type:
POWER Magnet Pallet
for HSC-Milling

SAV 220.31 - 320 x 320
Reference system*

