

## Electro Magnetic Chuck

SAV 243.42

With transverse pole pitch  $P = 13 \text{ mm}$ ,  $18 \text{ mm}$  and  $25 \text{ mm}$

This chuck is particularly notable for its high power, robust construction and long-life. The pole pitch gives real N and S-poles.

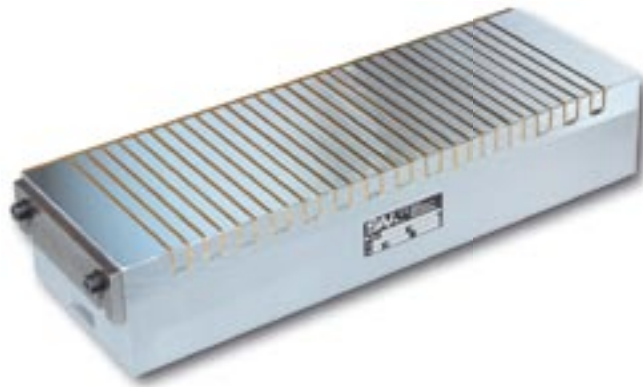

### Use:

For universal clamping of workpieces with form and positional tolerances of 0.01 to 0.02 mm.

- for workpiece positioning cross to pole pitch

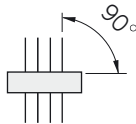

- for workpieces with min. thickness =  $x$ :  
 4.5 mm at  $P = 13 \text{ mm}$   
 6.0 mm at  $P = 18 \text{ mm}$   
 8.5 mm at  $P = 25 \text{ mm}$



- for flat workpieces with min. dimensions =  $a$ :  
 25 mm x 25 mm at  $P = 13 \text{ mm}$   
 32 mm x 32 mm at  $P = 18 \text{ mm}$   
 45 mm x 45 mm at  $P = 25 \text{ mm}$

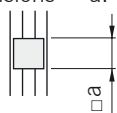

### Nominal holding force:

90 N/cm<sup>2</sup>, at pole pitch  $P = 13 \text{ mm}$   
 110 N/cm<sup>2</sup>, at pole pitch  $P = 18 \text{ mm}$   
 115 N/cm<sup>2</sup>, at pole pitch  $P = 25 \text{ mm}$   
 adjustable with control unit with encoded switch

### Option:

With especially superfine transverse pole pitch  
 1.9 mm steel; 0.5 mm brass for very thin workpieces.

90 V DC chuck voltage possible on request.

### Nominal operating voltage:

24 V DC up to 120 W  
 110 V DC for all sizes

### Features:

- solid constructed pole plate with either 13 mm, 18 mm or 25 mm pole pitch
- real magnetic (N/S) poles
- water cooling system on request
- air pressure release system on request for  $P = 18$  or  $25 \text{ mm}$
- gap free construction of pole plate
- fine grid pole plate to body connection
- 8 mm pole plate wearing limit
- mounting slots in both short faces
- through holes in sizes over 1000 mm length on specification
- robust and waterproof
- sealed to IP 65
- suitable for continuous (100%) operation
- for use with control unit type SAV 876.10 (see chapter 04)

### Auxiliary equipment:

- sidestop rail on short and long face
- connecting cable, 3 m, on the right-hand, short face
- lifting bolts on larger models

**WORKHOLDING AND AUTOMATION**

## Electro Magnetic Chuck

**SAV 243.42**

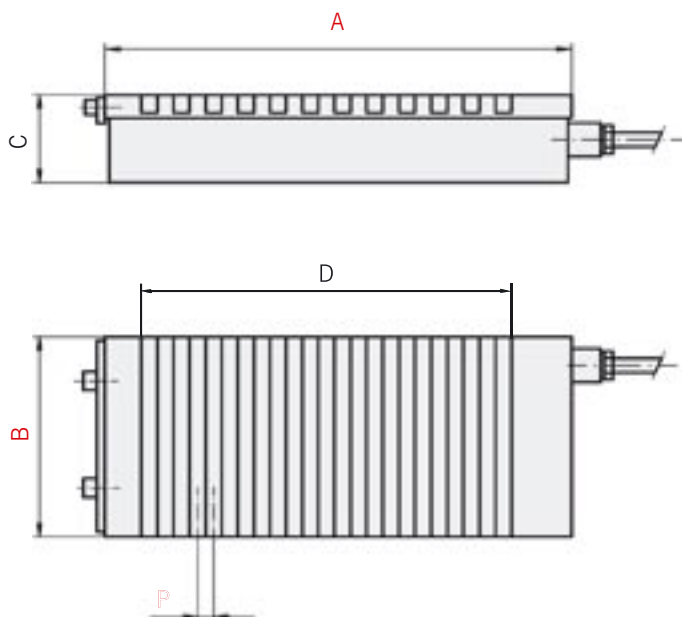
 With transverse pole pitch  $P = 13 \text{ mm}$ ,  $18 \text{ mm}$  and  $25 \text{ mm}$ 

Other sizes and operating voltages available on request. Larger clamping surfaces can be made by flush mounting several units. Please refer to chapter 04, SAV 876.10 to SAV 876.06, for details regarding suitable control units, based on the power rating (see chapter 04).

Dimensions in mm					Power rating in W	Weight in kg
A	B	C <sub>0</sub>	D	P		
200	100	90	120	13	19	11.0
300	100	90	224	13	31	17.0
300	150	90	224	13	42	25.0
400	150	90	328	13	52	34.0
450	175	90	381	18	64	44.0
400	200	90	309	18	66	45.0
500	200	90	417	18	83	56.0
600	200	90	525	18	89	67.0
800	200	90	741	18	120	90.0
500	250	90	417	18	94	70.0
600	250	90	525	18	109	84.0
800	250	90	741	18	127	112.0
500	300	90	417	18	110	84.0
600	300	90	525	18	128	101.0
800	300	90	741	18	171	134.0
1000	300	90	921	18	209	168.0
600	350	90	525	18	148	118.0
800	350	90	741	18	191	157.0
1000	350	90	921	18	239	196.0

Dimensions in mm					Power rating in W	Weight in kg
A	B	C <sub>0</sub>	D	P		
600	400	90	525	18	166	134.0
700	400	90	697	18	187	156.0
800	400	90	741	18	208	179.0
1000	400	90	921	18	255	224.0
1200	400	90	1101	18	329	269.0
800	500	90	730	25	254	224.0
1000	500	90	930	25	341	280.0
1200	500	90	1130	25	374	336.0
1250	500	90	1180	25	390	350.0
1500	500	90	1430	25	458	420.0
1600	500	90	1530	25	489	438.0
2000	500	90	1930	25	576	560.0
1000	600	90	930	25	361	382.0
1200	600	90	1130	25	441	459.0
1250	600	90	1180	25	459	478.0
1500	600	90	1430	25	487	573.0
1600	600	90	1530	25	520	611.0
2000	600	90	1930	25	607	764.0
1500	800	90	1430	25	730	764.0
1600	800	90	1530	25	693	815.0
2000	800	90	1930	25	810	1018.0

Ordering example: **Electro Magnetic Chuck SAV 243.42 - 2000 x 800 - 25 - 110 V**  
 Ordering key: Name SAV - No. - A x B - P - Operating voltage