

Electro Permanent Magnetic Chuck

SAV 243.72

With fine longitudinal pole pitch $P = 4 \text{ mm}$ and magnetizable stop rails

This newly developed clamping system with magnetic stop rails provides a simple, reliable and secure method for positioning and clamping workpieces for machining.

This helps to avoid positioning errors, particularly when used in multi-shift operation. The magnetic force is produced by permanent magnets that are magnetized and demagnetized by short electric current pulses. Especially suitable for thin parts.

Use:

Best suited for precision grinding of mass production components. For toolmaking, the system facilitates μm -precise machining with respect to the datum edge. Also for light milling.

- control of magnetizable side stops can be operated in time sequence

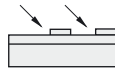

- for thin workpieces of up to 12 mm thick. (depends on height of stoppers)

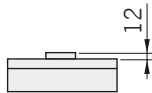

- for flat workpieces with min. dimensions 40 mm x 40 mm.

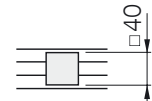

Nominal holding force:

100 N/cm²,
adjustable with control unit
with encoded switch

Nominal operating voltage:

360 V DC

Standard equipment:

- 1 or 2 magnetizable stop rails
- connecting cable, 3 m, on the right-hand, short face
- with industrial watertight plug-in type connector on request
- lifting bolts on larger models

Features:

- 2 strong bipolar magnets for the stop rails and 2 longitudinal pole magnets to provide accurate and secure alignment of the workpieces
- the magnetization of the stop rails takes place prior to that of the main clamping surface, using a special control routine. The workpiece is thus pulled firmly into the lower edge of the stop rail.

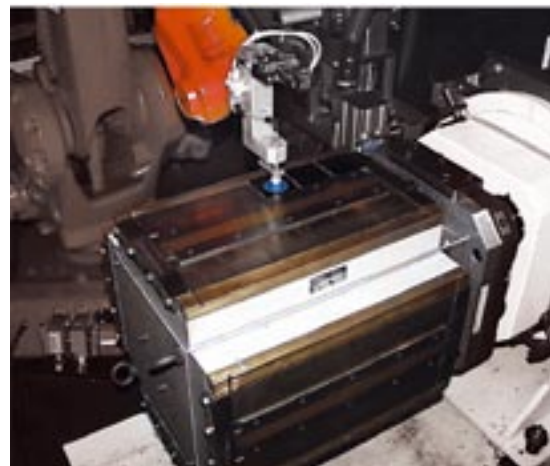
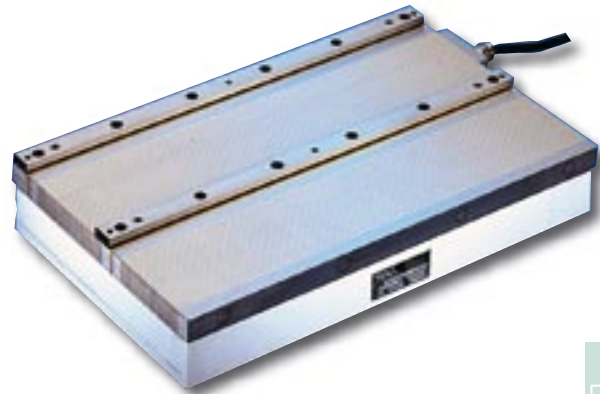

- especially fine, uninterrupted longitudinal pole arrangement
- glued lamination with additional pull anchors in length direction of chuck
- gap free construction of pole plate
- high precision due to fine grid pole plate to body connection
- switching off through demagnetizing cycle
- pole plate wearing limit 8 mm
- low magnetic field height
- heat treated tension free body
- electro-permanent system, guaranteeing safe operation during power failure
- mounting slots in both short faces
- extra enhanced systems available on request
- robust and waterproof
- sealed to IP 65
- for use with control unit type SAV 876.10 (see chapter 04)



WORKHOLDING AND AUTOMATION

Electro Permanent Magnetic Chuck

SAV 243.72

With fine longitudinal pole pitch $P = 4$ mm and magnetizable stop rails

The magnetizing cycle starts with magnetizing just the stop rails. The workpiece is thus pulled with a force F_A , at an angle of 45° , into the corner between the stop rail and the chuck surface.

Approximately 1 second later, the main chuck surface is switched on to generate the main clamping force F_H .

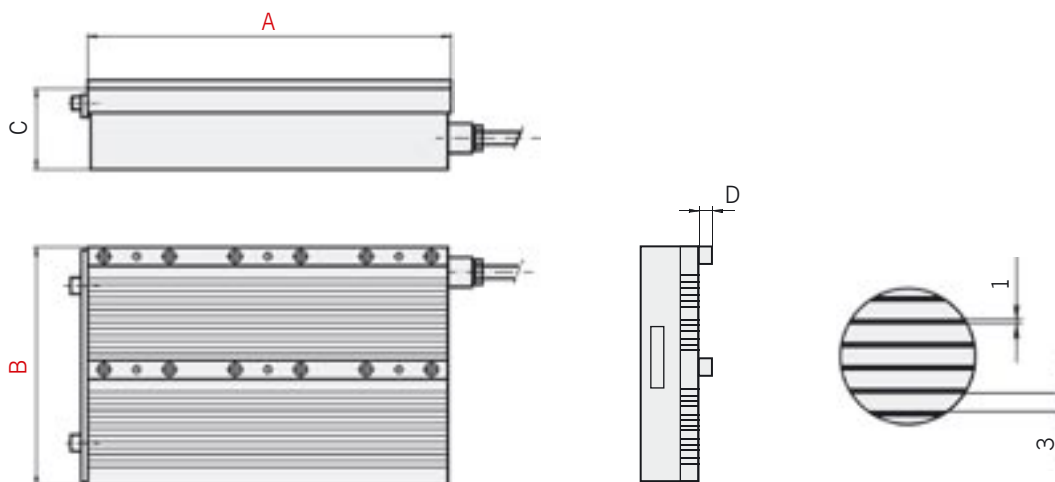
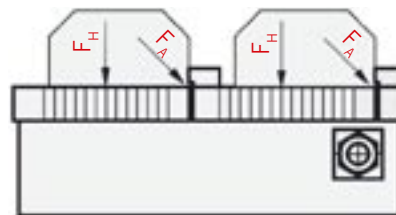

Dimensions in mm				Number of stop rails	Weight in kg	Control unit max. current in A	Suitable control unit
A	B	C ₁	D*				
400	200	77	12	1	45.0	30 x 2	876.10
500	200	77	12	1	56.0	30 x 2	876.10
600	200	77	12	1	67.0	30 x 2	876.10
400	300	77	12	2	68.0	30 x 2	876.10
500	300	77	12	2	86.0	30 x 2	876.10
600	300	77	12	2	103.0	30 x 2	876.10
600	400	77	12	2	137.0	30 x 2	876.10
800	400	77	12	2	183.0	30 x 2	876.10

*Other heights on request. The table gives a summary of the standard sizes available. Custom-made versions are available on request. Please refer to SAV 876.10 for control unit details.

Ordering example: **Electro Permanent Magnetic Chuck SAV 243.72 - 800 x 400 - 360 V**
 Ordering key: Name SAV - No. - A x B - Operating voltage