



WORKHOLDING AND AUTOMATION

Control Unit

SAV 876.02

For switching of direct current magnets in connection with polarity reversing unit type SAV 876.10

Application:

For switching of direct current magnets in connection with electronic polarity-reversing control unit SAV 876.10. The control unit is switched on by pushing the green illuminated push button. The polarity-reversing process is initiated by a red illuminated push button. Possible fault indications as monitored by the polarity-reversing unit are also presented to the red illuminated push button by means of a coded blinking signal. Required holding force can be selected using the 8 level coding switch (16 levels on request).

Execution:

In order to comply with accident prevention regulations for machine tools, the release of the machine feed through auxiliary contacts can only be authorised when magnet is switched on and when the "on" position is indicated by a signal light.

This control unit complies with these regulations.

The signal lamp is integrated into the push button of the control unit.

The auxiliary contacts (interlock) for the machine feed are integrated in the polarity-reversing control unit.

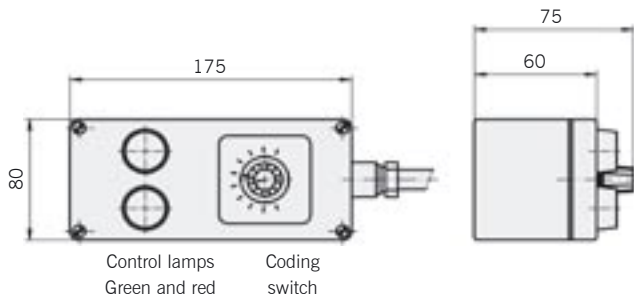
**Control unit type SE1**

With coding switch for holding force setting in 8 levels using inverse BCD-coding, including 2 integrated signal lamps and 2 m coded cable, 9 pole. Additional coded cable against price adder.

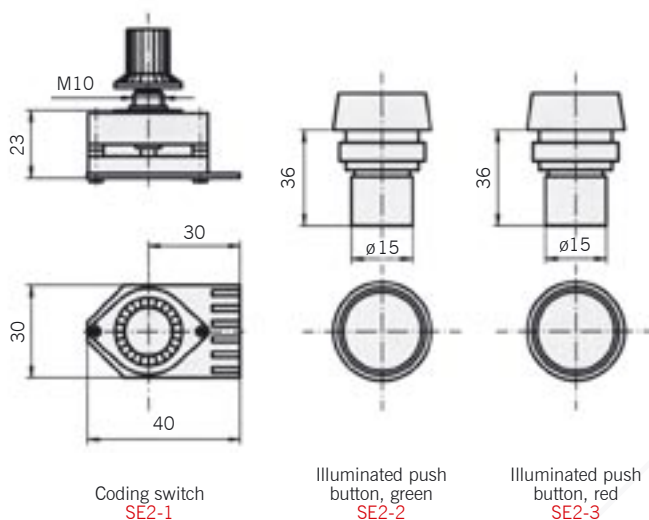
**Build-in version type SE2-1 to SE2-3**

Consisting of 2 signal push buttons and coding switch for holding force setting in 8 levels using inverse BCD-coding. Complete set can be ordered under type SE2-S.

Ordering example: Control Unit SAV 876.02 - SE2-1
Ordering key: Name SAV No. - Type