

Laminated Circular Top Plate

SAV 248.01

For use on circular chucks with parallel pole arrangement

Use:

Clamping of profiled workpieces on circular chucks with parallel pole arrangement. Only usable in conjunction with circular magnetic chuck SAV 244.02 and 244.05.

Features:

Silver brazed steel/brass construction. Can be machined to any required shape, or custom machined during manufacture. Connection to magnet to be agreed upon.

Pole pitch: steel 3 mm, brass 1 mm

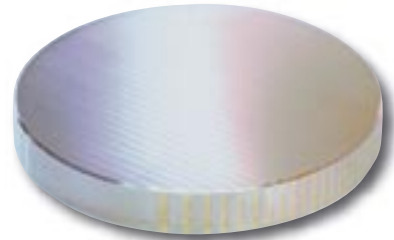

Dimensions in mm			Weight in kg
A	B		
155	25		4.0
200	25		6.0
250	25		10.0
300	25		14.0
350	25		19.0
400	30		30.0
450	30		37.5
500	30		46.0

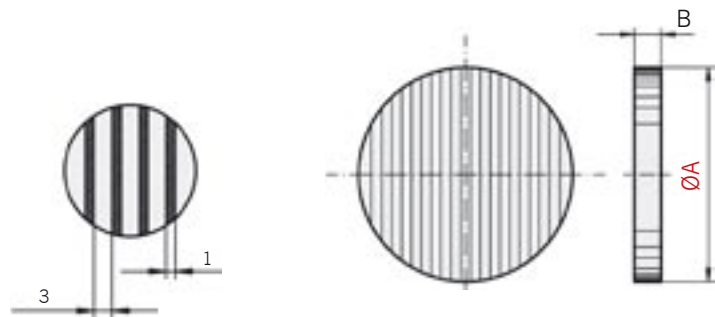

Ordering example: Laminated Circular Top Plate SAV 248.01 - 500
 Ordering key: Name SAV - No. - A

Laminated Bars

SAV 248.02

For use on magnetic chucks with transverse pole arrangement

Use:

To provide a suitable mounting surface for difficult workpieces. Only usable in conjunction with a magnetic chuck with a transverse pole arrangement.

Suitable for SAV 243.11, 243.12, 243.40, 243.42, 243.70 and 243.73.

Features:

The silver brazed pole plates can be machined to any desired shape.

Pole pitch: steel 3 mm, brass 1 mm

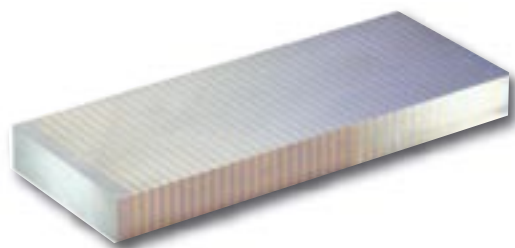

Dimensions in mm				Weight in kg
A	B	C		
250	150	25		7.5
300	150	25		9.0
400	150	25		12.0
300	200	25		12.0
400	200	25		16.0
250	250	25		12.5
400	250	25		19.5

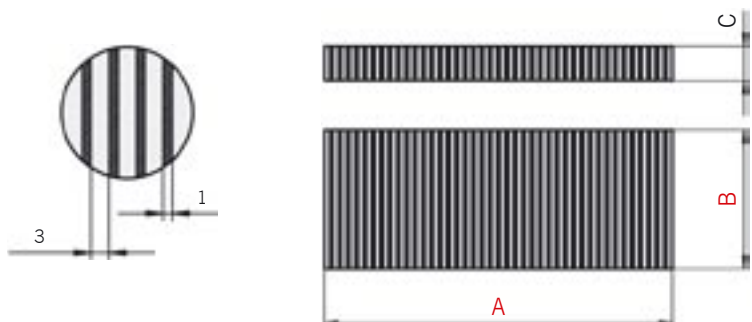

Custom sizes on request.

Ordering example: Laminated Bar SAV 248.02 - 250 x 150
 Ordering key: Name SAV - No. - A x B