



WORKHOLDING AND AUTOMATION

Hydro Machine Vice

SAV 233.72

For high clamping forces

**Application:**

For rigid and accurate clamping, especially recommended for use in vertical machining centres. These vices can be exactly positioned on all machine beds provided with keyways. Extra-Large clamping ranges which are achieved using step jaw inserts ensure optimum utilisation of the machine travel.

Guideways inductively hardened and ground.

**Functional description:**

- keyways in longitudinal direction and across the length for quick and precise positioning
- infinitely variable clamping force with mechanical-hydraulic-system
- high precision
- compact design with integrated spindle and force transmission giving an optimum protection against chips and dirt
- quick adjustment with socket pin
- mounting threads for workpiece stop (optional extra)
- keyways and threaded holes on slide and fixed jaw for an extension of the clamping range
- rapid and safe fastening using clamping claws
- wide range of accessories

**Scope of supply:**

- reversible standard jaws, plain / serrated
- crank handle
- operating instructions

**Optional extras:**

- wide range of standard jaws SAV 233.80
- step jaw inserts SAV 233.80 - ASB
- quick insert jaws SAV 233.81

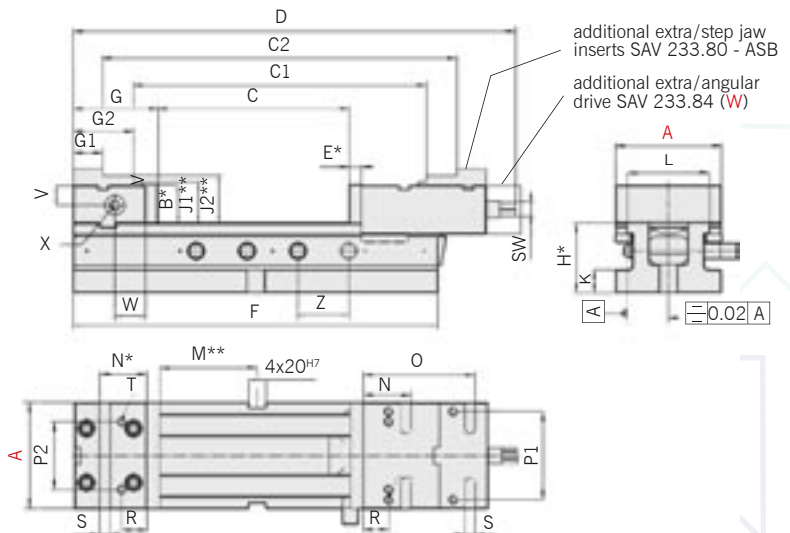
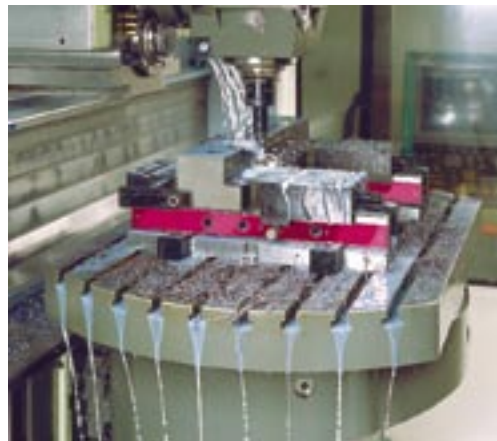
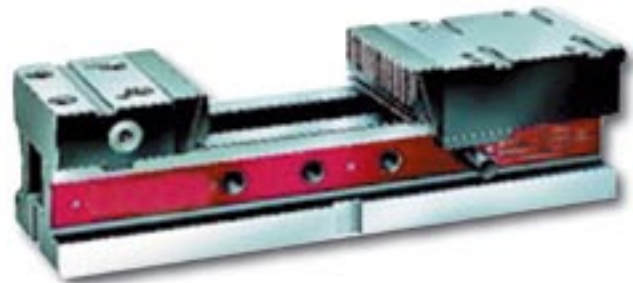
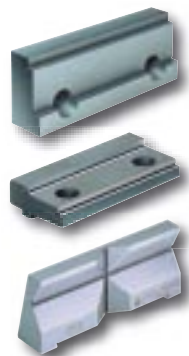

Dimensions in mm																Max. clamping force in kN	Weight in kg
A	B	C	D	E*	F*	G	H*	K	L <sub>g6</sub>	M**	V	W	X	Z	SW		
100	380	205	464	34	13	80	70	24	78	110	17.5	35	M12 x 18	58	14	25	18.5
125	430	225	526	45	15	100	82	27	98	115	23.0	36	M12 x 18	60	17	40	31.5
160	550	309	684	54	18	120	95	27	125	155	27.0	50	M20 x 27	80	19	50	58.5

Dimensions for use with step jaw inserts in mm													
A	C1	C2	G1	G2	J1**	J2**	N	O	P1	P2	R	S <sub>H7</sub>	T
100	330	386	28	56	40	45	45	122	83	65	25	10	M8 x 12
125	363	431	35	69	53	58	56	132	104	80	30	12	M10 x 13
160	503	573	37	72	65	70	73	171	130	100	45	18	M12 x 16

\* Tolerance = ± 0.01  
\*\*Tolerance = ± 0.02

Ordering example: Hydro Machine Vice SAV 233.72 - 125 - W  
 Ordering key: Name SAV-No. - A - Angular drive (optional)