

Precision Wheel Side Dresser

SAV 434.06

For dressing the side faces of grinding wheels

Use:

For dressing the side faces of grinding wheels, for grinding slots; setting from 0.5 to 28 mm.

Design:

Produced from hardened tool steel HRC 60. Available with (K) or without (N) cooling system on request.

Accessories:

Diamond dresser; SAV 401.01-08, Type D available against price adder.

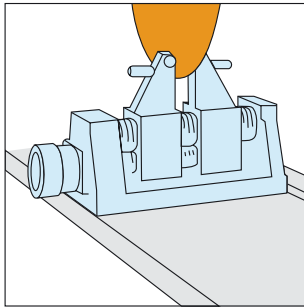

Wheel-Side Dresser SAV 434.06-K, with cooling system

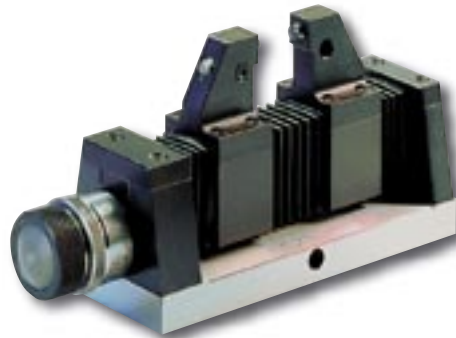

Wheel-Side Dresser SAV 434.06-N in normal execution, without cooling system

Base plate	mm	190 x 65
Height	mm	115
Setting range	mm	0.5 - 28
Max. wheel thickness	mm	50
Setting resolution per side	mm	0.005
Setting resolution thickness	mm	0.010
Bore for diamond	mm	8
Weight	kg	5.0

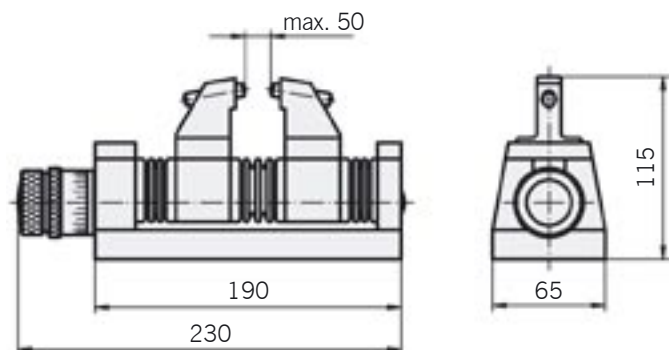

Ordering example: Precision Wheel Side Dresser SAV 434.06 - K
 Ordering key: Name SAV No. - Execution